

BASIC FITMENT CRITERIA UK & EU SPECIFICATIONS

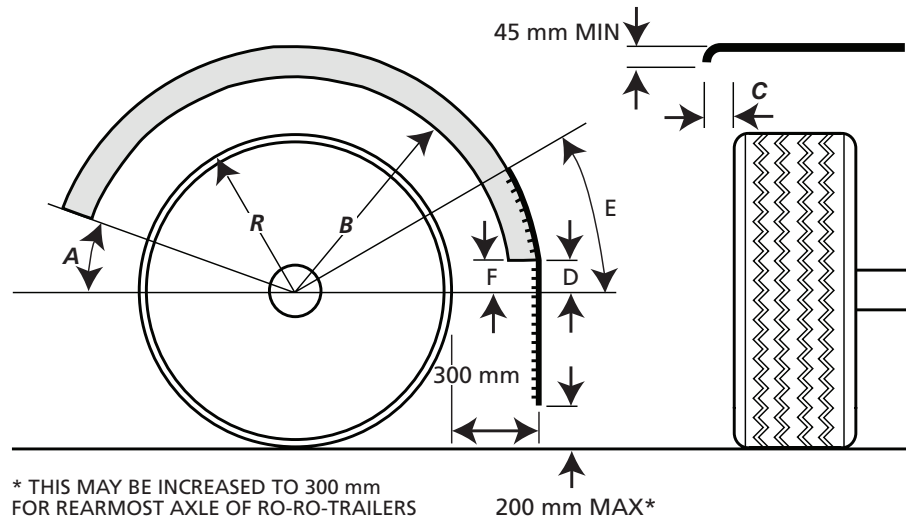

Twin & Tri Axles

If the gap between the tyres is less than 250mm, a flap on the rear mudguard only is necessary.

Flap Width

The flap should cover the full breadth of the tyre(s), except inside the mudguard, where it must cover the tyre tread(s) as a minimum.

BASIC FITMENT CRITERIA UK & EU SPECIFICATIONS

SIZE	NON STEERED	STEERED
Dimension A	20° Maximum	30° Maximum
Dimension B	1.25R Maximum	1.5R Maximum
Dimension C	75mm Maximum	100mm Maximum
Dimension D	100mm Minimum UK specification or	100mm Minimum UK specification or
Dimension E	30° Minimum Euro specification	30° Minimum Euro specification
Dimension F	100mm Maximum	100mm Maximum

FLAP VALANCE

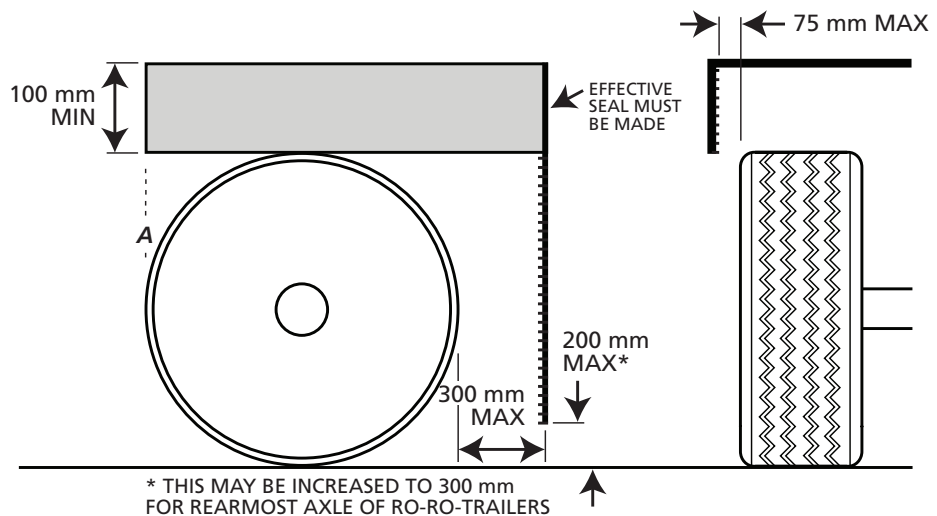

Twin & Tri Axles

If the gap between the tyres is less than 250mm, a flap behind the rear most axle only, is necessary. However, the valance must continue and span the full length from Point A (see drawing) through to the flap behind the rear most axle.

Flap Width

The flap must cover the entire tyre breadth.