

FRONT LOADING FIRE EXTINGUISHER CASES

- All Plastic Construction, Non-Corrosive.
- Lightweight.
- Viewing Window.
- Internal Extinguisher Strap.
- Suitable for most 6KG and 9KG Extinguishers.
- Fully Certified

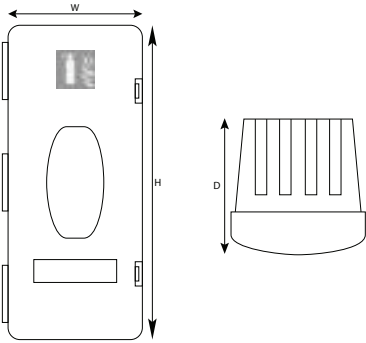

FRONT LOADING FIRE EXTINGUISHER CASES

| PART NO. | WIDTH (W) | HEIGHT (H) | DEPTH (D) | DESCRIPTION |
|--------------------|-----------|------------|-----------|--|
| BJB-RB155 | 290mm | 690mm | 260mm | Front Loading Extinguisher Box Including Internal Strap and Viewing Window Suitable For Most Extinguishers Up To 9kg |
| BJB-RB155-B | 290mm | 690mm | 260mm | As Above but in Black |

PREMIUM FIRE EXTINGUISHER AND SPILL KIT CASES

- Moulded from heavy duty polyethylene.
- Inspection Window on BJB24E and BJB25ES.
- Moulded-in fixing points.
- Ideally suited to the Petrochemical Industries.
- Available as a dedicated Fire Extinguisher and Spill Kit Case or as a Dual Purpose Box.
- Fitted with water resistant seal.
- Fully Certified

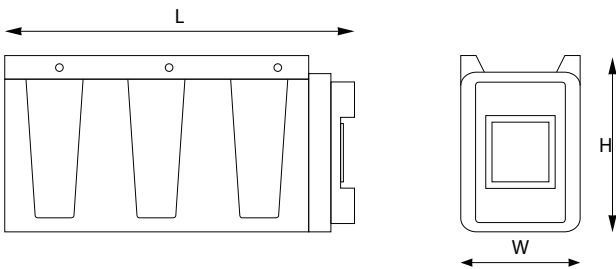

PREMIUM FIRE EXTINGUISHER AND SPILL KIT CASES

| PART NO. | WIDTH (W) | HEIGHT (H) | LENGTH (L) | DESCRIPTION |
|----------------|-----------|------------|------------|---|
| BJB24E | 250mm | 290mm | 735mm | 9 kg Fire Extinguisher Box with Window |
| BJB25ES | 250mm | 370mm | 735mm | Dual Purpose Spill Kit & 6 kg Fire Extinguisher Box |

All dimensions nominal.

The manufacturer reserves the right to alter sizes, specifications etc. without prior notice