

## TOP LOADING FIRE EXTINGUISHER CASE

- Lightweight – manufactured from Polyethylene.
- High chemical and impact resistance.
- Waterproof seal.
- Internal Extinguisher restraining strap.
- Easy fitment.
- All fixings coated with anti-corrosive protection.
- Fully Certified

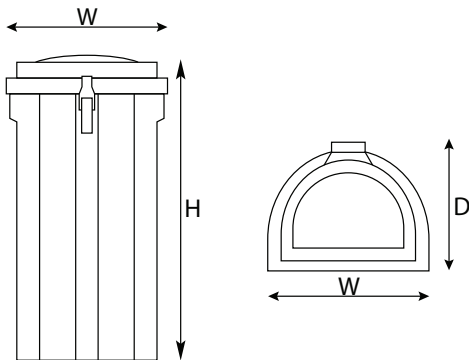

### TOP LOADING FIRE EXTINGUISHER CASE

PART NO.	WIDTH (W)	HEIGHT (H)	DEPTH (D)	DESCRIPTION
<b>BJB18EF</b>	310mm	675mm	280mm	Top Loading Spill Kit Case Complete with all Bracketry
<b>BJB18E</b>	310mm	675mm	280mm	Top Loading Fire Extinguisher Case Only
<b>BJB18FIX</b>				Fixing Bracket Kit to suit BJB18E

Compatible with most 6Kg, 9Kg & 12Kg Fire Extinguishers

## EXTINGUISHER AND SPILL KIT COMBI-BOX

- Dual Purpose Extinguisher and Spill Kit Case.
- Moulded from heavy duty polyethylene.
- Suitable for Extinguishers up to 9 kg.
- Water resistant seal.
- Fully Certified

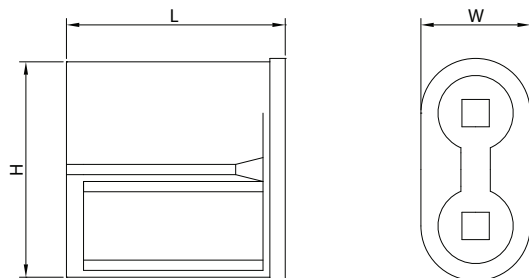

### EXTINGUISHER AND SPILL KIT COMBI-BOX

PART NO.	WIDTH (W)	HEIGHT (H)	LENGTH (L)	DESCRIPTION
<b>BJB22ES</b>	320mm	650mm	640mm	Dual Purpose Extinguisher and Spill Kit Case with Brackets

All dimensions nominal.  
The manufacturer reserves the right to alter sizes, specifications etc. without prior notice